



Warranty

The Company warrants this product to the original purchaser to be free from defects in workmanship and materials under normal use and service (all except human matters) for 1 year from the date of receiving.

 **Airdogpro**
Follow and like us on facebook

 **Airdogpro**
Follow us on twitter

 **AirdogUSA**
Follow us on Instagram

 Customer Service : support@siliconvalleyairexperts.com

 Official Website : <http://airdogusa.com/>



Scan QR code for more Video Instructions
(Airdog Youtube channels)



Please Recycle

Airdog X5

GUIDE

Silicon Valley Air Expert





Higher Efficiency



Real-time Data



Child Lock



Budgets



Low Noise



Automatically
Adjusts



No HEPA



App Controlled



About Airdog X5

We pushed the bounds of air purification technology to develop a best-in-class air purifier that combats the indoor air pollutants found in every building. An optimized aerodynamic design enables high-volume airflow so that your air gets cleaner, faster and more quietly.

The Airdog X5 air purifier puts your health and the health of the environment first. You'll stop inhaling everyday indoor air pollutants and breathe cleaner air than with any of the more traditional air purifiers on the market (like HEPA). Plus you'll save time, money, and the planet with our energy-efficient and WASTE-FREE design.

No more HEPA filters, just wash.



Easy-to-wash in a dishwasher or by hand.

Packing List

Air Purifier Main Body × 1 Collecting Plates × 1 Remote Control × 1 Cleaning Brush × 1

Components

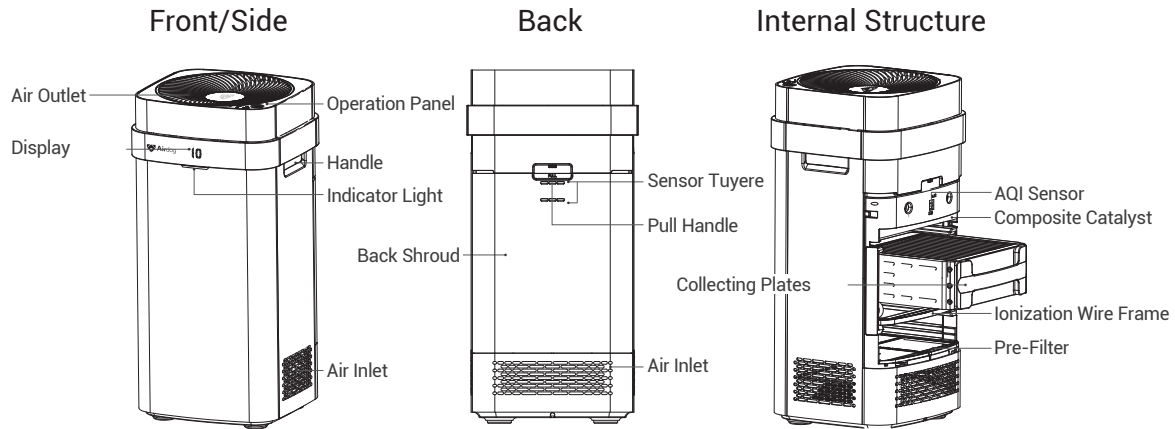

Installation Guide

1. Take the collecting plates out of the foam box
—If any styrofoam packaging pieces are on the plates, blow or brush them out before installing the collecting plates;
2. Use the pull handle to open the back shroud (Pic1);
3. Insert the collecting plates in the orientation described on the label (Pic2);
4. Close the back shroud and place the air purifier in an open location to achieve the best cleaning effects.

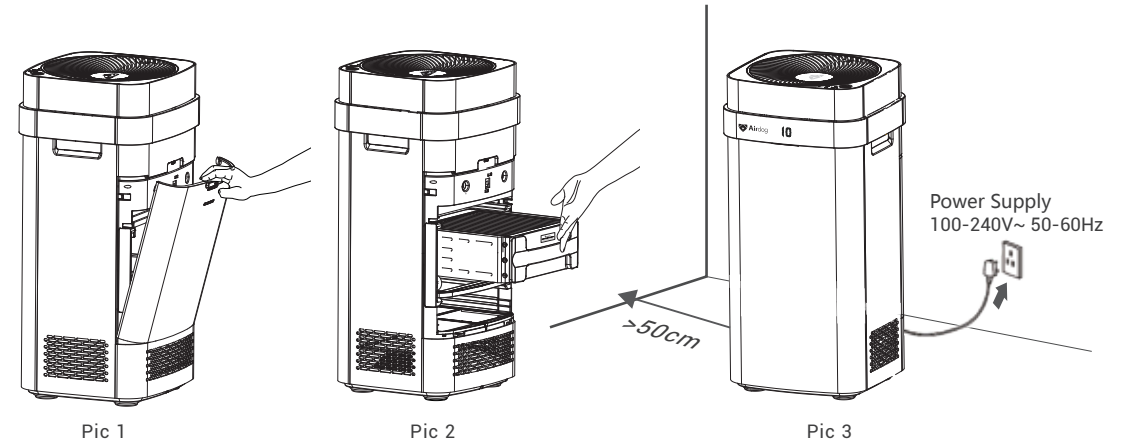

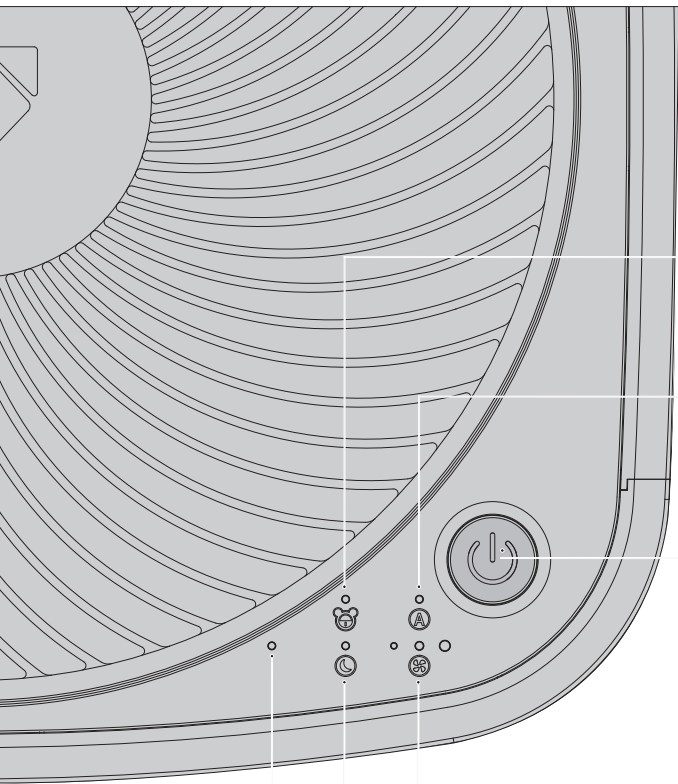

Air Purifier Operation Instruction

Child Lock Indicator

To avoid children's playful operation, under this mode the operation button is locked. The air purifier could only be controlled or unlocked by the remote control or APP. Use remote control or APP to turn on the child lock mode.

Auto Mode Indicator

When this light on, the air purifier is running under automatic mode. It automatically senses the air quality and adjusts its running speed according to the air quality level. This is the most energy efficient mode and we recommend keeping the purifier in this mode most of time.

Power Switch

A short press (approximately 1 second) turns the power ON. A long press (over 3 seconds) turns the power OFF. When power is ON, each short press cycles through auto-mode ON/OFF, different fan speeds, sleep mode, etc... Check indicator lights to understand each operation mode.

Wind Speed Indicator Light

Left Light : Slow Mode
 Middle Light : Mid-speed Mode
 Right Light : High Speed Mode
 ALL Lights : Turbo Mode

WiFi Light (Blue Light)

When the indicator is flashing the purifier is in pairing mode;

Sleep Mode Indicator

In sleep mode, your air purifier is still cleaning your air but in quieter low-speed mode. Also to avoid light disturbance, all display lights are OFF.

Display and Air Quality Indicator Instruction



Green:
 Excellent
 AQI ≤ 50



Yellow Green:
 Good
 50 < AQI ≤ 100



Yellow:
 Moderately Polluted
 100 < AQI ≤ 150



Red:
 Hazardous
 AQI > 150

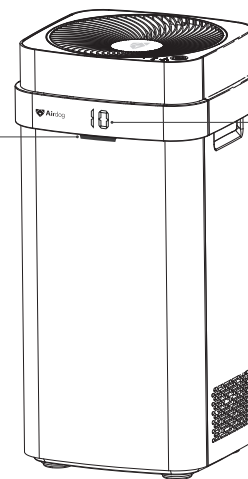

AQI (Air Quality Index)
 this is a calculated air quality index based on the particle numbers that the sensor measures in the air. Ranges from 0-500.



Wind Speed Indicator
 L1-L4, slow to fast.



Cleaning reminder
 When "C" appears on the display instead of AQI numbers, it reminds you to wash the collecting plates. Press and hold the "Reset" button for 6 seconds to cancel the reminder once the collecting plates are washed or cleaned.



Fault Display
 When "9XX" appears on the display instead of AQI numbers, clean the unit and make sure to put every part back correctly and make solid contact. Please move to the Full Cleaning Cycle section for more cleaning details.
 If "9XX" is still on the display after cleaning, please contact AirDog Team: support@siliconvalleyairexperts.com for further help.

AQI numbers are calculated based on the real time particles numbers in some air volume according to United States Environmental Protection Agency(EPA). The numbers could be affected by the air flow speed, air purifier position and ambient environment. AQI is an indicator of air quality. As the AQI increases, an increasingly large percentage of the population is likely to experience increasingly severe adverse health effects.

Air Quality Sensor Cleaning

Airdog air purifier has an embedded air quality sensor. To keep the air quality sensor reading correctly, please clean the sensor as illustrated every 6 months, using dry or with rubbing alcohol cotton swabs as illustrated.

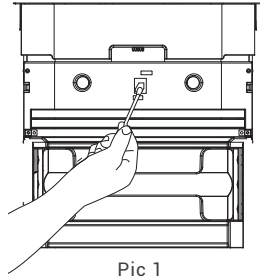

Pic 1

Ionization Wire Frame Cleaning

1. We recommend you to clean the Ionization Wire Frame when the air purifier appears abnormal sounds, such as "popping or cracking" .
2. Use soft cloth or sponge to clean the Ionization Wire Frame track by sliding up-down gently.
3. Insert the Ionization Wire Frame in the direction of labeling.

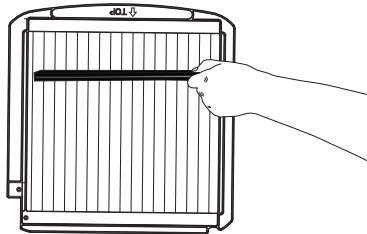

Pic 1

Collecting Plates Cleaning

1. We recommend you to clean the collecting plates when the air purifier display "-[-" .
2. Cut the power, open the back shroud and pull out the collecting plates (Pic 1) .
3. Put collecting plates into a container and use a cleaning brush to clean external sheet metal finishing by water (Pic 3).
Remarks: a. It is better to use detergent and soak for around 10 mins before brushing the collecting plates. Do not soak for too long in order to protect the normal functions of collecting plates (Pic 2).
b. Choose the neutral detergent. DO NOT USE corrosive detergent, such as daily laundry powder.
c. Do ignore the small stains on the surface of the sheet metal as it will not seriously affect the use of the air purifier.
4. Dry the collecting plates after cleaning, it can either use hair dryer or the nature sunlight (recommend over 24 hrs).
5. Put back the collecting plates in the direction of labeling.

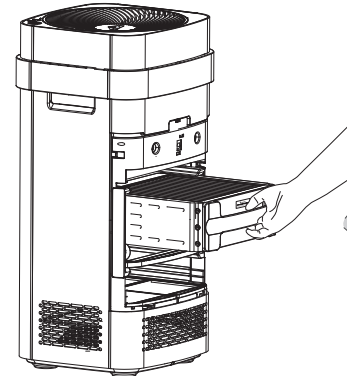

Pic 1

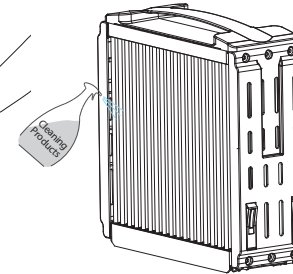

Pic 2

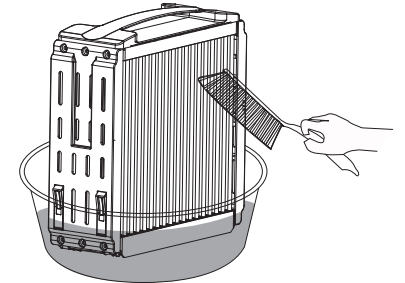

Pic 3

Full Cleaning Cycle

1. We recommend a complete cleaning every 6-12 months.
2. First, unplug the power supply. Open the back shroud, pull out the ionization wire frame and collecting plates. Pull out the protective rubber sleeve as illustrated in (Pic 1).
3. Clean the ionization wire frame and collecting plates properly according to the previous instructions.
4. Use a wet cloth to wipe down all surfaces of the protective rubber sleeve, including notches. For better result, wash the entire rubber sleeve in water.
5. Clean the inner walls of the air purifier with a wet cloth.
6. Wash the pre-filter in water, or clean it by vacuum.
7. Dry the parts completely, then put them back in order.

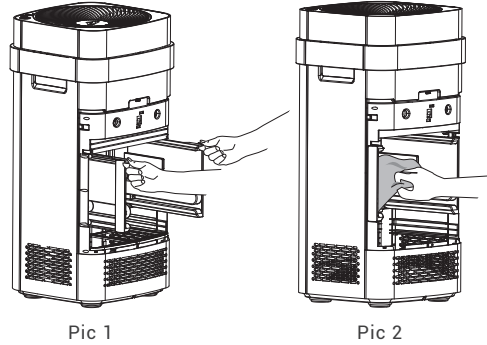

Pic 1

Pic 2

Catalytic Gauze Cleaning

The composite filter is composed of a composite catalyst, and active carbon. In principle the catalyst is not involved in the reaction and should not be changed. However, if the catalyst becomes coated with dust, odor or moisture then the catalytic effect will decrease. Protect the device with the provided cover whenever it is not powered up to help extend the catalyst life. A periodic sunbath for 1-2 hour may also help to reduce the moisture build up and reactivate the catalytic effect.

The shelf life of the composite filter depends on how much you use the purifier. Change the composite every year or two, or whenever you notice a significant decrease in the purifier's ability to remove odors from the air.

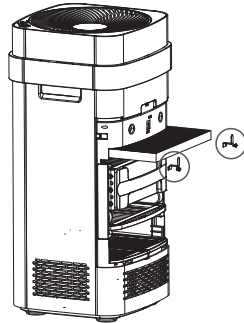

Pic 1

CL20170510-01

Note:

Please make sure the power has been cut off before any cleaning and maintenance

App Setting

Please keep your Wi-Fi on to help you finish your App setting.



iOS

Scan to download



Android

Scan to download

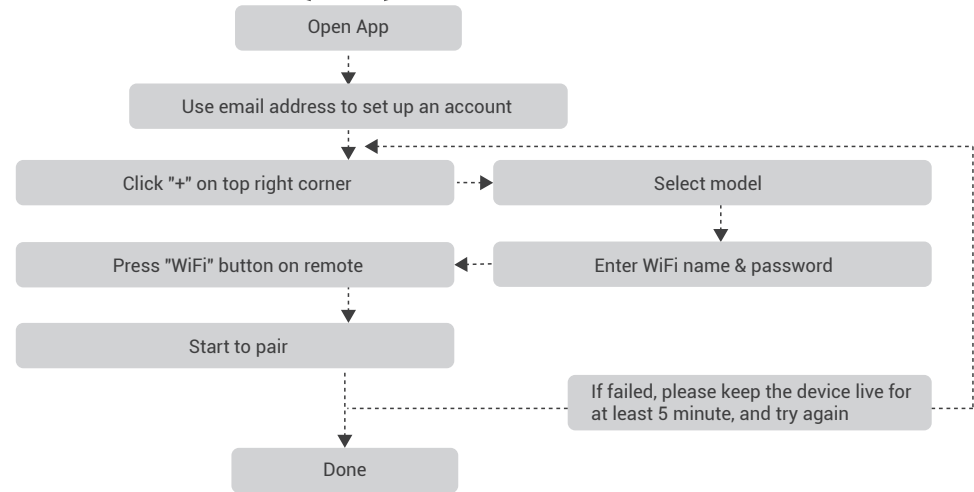

For convenience, please check Airdog youtube channel for video instructions.

Q&A

Q1: I am concerned about the product safety, may I know more details?

Airdog X5 is built around Safety 1st! We have implemented the following:

- A.Smart control: The “smart electronics” control circuit continually monitors the current and voltage levels, and suppresses them whenever there’s any abnormal situation;
- B.Anti-fire: Airdog X5 is manufactured with the highest V0-grade fire retardant plastics housing;
- C.Child lock: It prevents improper operations when children are playing around it;
- D.International reputable third-party verification: Airdog X5 has passed safety test requirements including but not limited to CE, FCC, CQC etc.

Q2: Airdog X5 uses high voltage inside, is it safe for home use?

Airdog X5 uses an advanced electronic design built around safety. The power consumption of Airdog is equivalent to a small light bulb. It has high voltage inside but very low current in the order of micro-amps. The high voltage runs on direct current to avoid any possible electronic perturbation.

Q3 : Do I have any maintenance cost if I own an Airdog X5?

Airdog X5 is a cost effective and environmental green solution.

- A.Collecting plates in Airdog X5 is washable and reusable, so no more spending on HEPA filters and others.
- Composite catalyst gauze is reusable, you may put it directly under the sunlight for 1~2 hours to refresh it. However, some customers might be very sensitive to any smell and might have to change the composite catalyst layer every 6-24 months to refresh the smell. The cost of the catalyst layer is only a small fraction of the cost of HEPA. To replace the catalyst layer, please contact your sales resource where you bought Airdog X5.

Q4: How could I know that my air purifier is cleaning the air?

The best part of Airdog X5 air purifier is that you could see the effect by your own eyes! You will notice the AQI (Air Quality Index) number decreasing when the air purifier is on. Also, after using X5 for a week, you can actually see many of the pollutants absorbed on the collecting plates when you take the plates out of X5 to clean.

Q5: Why the AQI display is abnormal on LCD screen, display “-C-” or “9XX” instead of digits?

Display of “-C-” means it is time to do a cleaning.

The “9XX” is an electronics abnormal signal. Please unplug the unit and do a full clean cycle and restart. If the “9XX” still exists, please contact customer service for further instructions.

Q6: Why isn't the AQI display changing number?

The dust accumulated on the sensor could cause insensitivity of sensors. Please clean the sensor with a dry cloth or a cotton swab with alcohol.

Q7: I heard a “cracking” or “zapping” noise inside the unit. Is that normal?

The occasional “zapping” or “cracking” is normal when the bigger particles enter the air purifier, being zapped by the high voltage, similar to when a bug zapper traps a bug. However, if the “cracking” or “zapping” noise is constant, you should clean the unit and make sure that all parts in the unit are fully dried after you clean the unit. 80% of the noise issues are caused by dust accumulation on the collecting plates and/or inner chamber, or by wet collecting plates. Normally a full clean cycle will take care of this all.

Q8: When should I do a full cleaning cycle?

- A.When “-C-” is on the display screen.
 - B.“9XX” appears on the display screen even after cleaning the collecting plates.
 - C.Cracking sounds still exist after cleaning the collecting plates.
 - D.The unit shuts down and restarts automatically.
- Note: Please refer to the “Full cleaning cycle” section in the user manual for details.

Q9: Can I clean Airdog X5 by putting the whole unit in the dishwasher?

You should not put the whole Airdog X5 unit into the dishwasher! Only the collecting plates is OK to be washed by a full wash cycle. Please make sure the collecting plates unit is fully dried before putting it back into your Airdog X5. There could be water residue inside of the collecting plates even after the drying cycle sometimes, so make sure to take the time to fully dry them.

Q10: How could I confirm that the collecting plates is fully dried?

Please put the collecting plates in a dry space for at least 24 hrs. You may put tissues or a paper towel under the collecting plates to check if it is fully dried.

Q11: Why does Airdog App connection fail?

- A.Airdog App does not support IPv6 network environment.
- B.Make sure your Wi-Fi is in 2.4GHz.
- C.The home Wi-Fi environment could be complicated. To verify if the smart control system is functional or not, you could use the hotspot on another phone instead of the home Wi-Fi to make a connection. The hotspot could simplify connection complexity and verify the hardware function.
- D.We have finished the App and server migration. Please double check the label on the back of the unit, if it is a green matrix code, you are good to download the “Airdog Pro”App and connect. If it is a blue matrix code, please check whether your firmware is upgraded or not.

For more details, please visit the Official Website for the App Guide.

FCC Statement

This device complies with Part 15 of the FCC Rules.

Operation is subject to the following two conditions:

- (1) this device may not cause harmful interference, and
- (2) this device must accept any interference received, including interference that may cause undesired operation.

CAUTION: Changes or modifications not expressly approved by the party responsible for compliance could void the user's authority to operate the equipment.

For a Class B digital device or peripheral, the instructions furnished the user shall include the following or similar statement, placed in a prominent location in the text of the manual:

NOTE: This equipment has been tested and found to comply with the limits for a Class B digital device, pursuant to Part 15 of the FCC Rules. These limits are designed to provide reasonable protection against harmful interference in a residential installation.

This equipment generates, uses and can radiate radio frequency energy and, if not installed and used in accordance with the instructions, may cause harmful interference to radio communications.

However, there is no guarantee that interference will not occur in a particular installation. If this equipment does cause harmful interference to radio or television reception, which can be determined by turning the equipment off and on, the user is encouraged to try to correct the interference by one or more of the following measures:

- Reorient or relocate the receiving antenna.
- Increase the separation between the equipment and receiver.
- Connect the equipment into an outlet on a circuit different from that to which the receiver is connected.
- Consult the dealer or an experienced radio/TV technician for help.

RF exposure warning

This equipment must be installed and operated in accordance with provided instructions and must not be co-located or operating in conjunction with any other antenna or transmitter. End-users and installers must be provided with antenna installation instructions and transmitter operating conditions for satisfying RF exposure compliance.



Technical Specification

Model	KJ300F-X5
Applicable area	375 SQF or 35 m ² *
CADR _{Particle}	200 CFM or 350 m ³ /h *
Noise (dB(A))	≤63
Rated Power (W)	55
Power	100-240V~ 50-60Hz
Weight (kg)	10.7
Size (m)	0.65 (H) *0.316 (L) *0.306 (W)

*Test according to GB/T 18801-2015



Designed by Silicon Valley Air Expert
Manufactured by Anhui BeiAng Air Tech Ltd.
No.15, Exi Rd., San Shan District, Wuhu, Anhui